

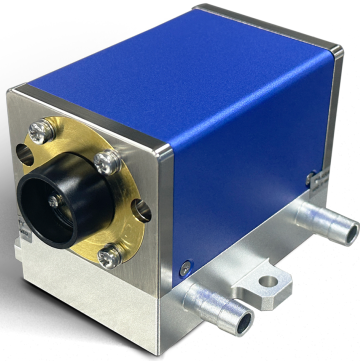

CW Diode-Pumped Solid-State Laser

Lumispot OEM DPSS Laser Solution

01 Features



High-power
pumping capability

High Gain
Uniformity

Macrochannel
water cooling

Low Maintenance
Cost

Compact Design

Long Lifespan

02 Applications



Nano/picosecond
laser amplifier



High-gain Pulse-
Pumped Amplifier

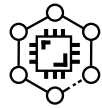

Micro-nano
Fabrication



Laser Cutting



Environment



Meteorology



Medical

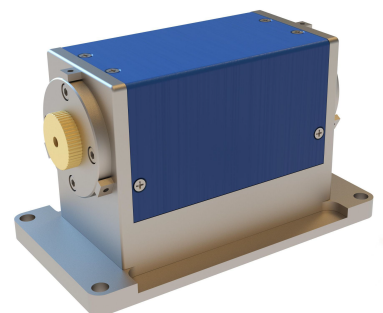
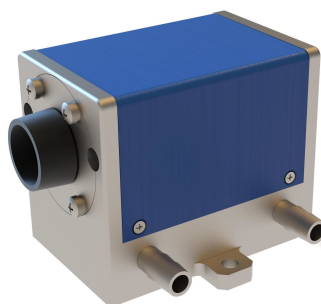
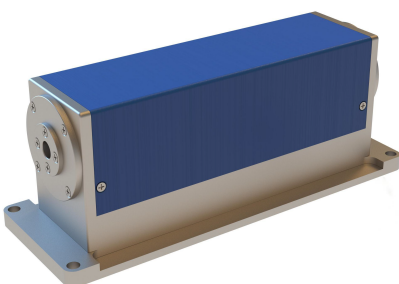
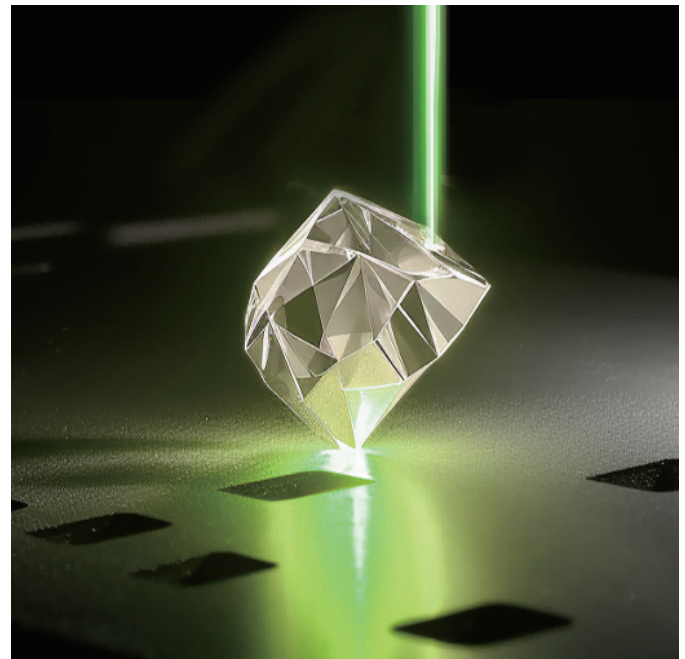

CW Diode-Pumped Solid-State Laser

Technical Datasheet

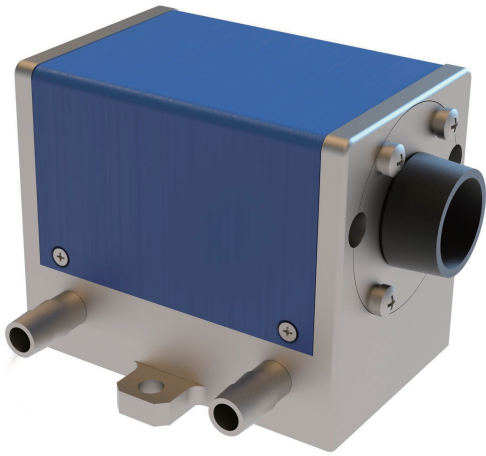

C240-3 C270-3 C300-2 C300-3 C600-4 C1500-5 Remarks

Pump Wavelength	808±3						@25°C water temp.
Pump Spectral Width	4						
Wavelength/Temp. Coefficient	0.28nm/°C						Customizable Power Options
Rated Pump Power	270W	270W	300W	300W	1000W	1500W	
Threshold Current	8A	8A	15A	8A	8A	8A	
Operating Current	20A	20A	25A	25A	30A	30A	
Operating Voltage	24V	28V	24V	24V	40V	100V	
Nd:YAG Doping	0.6at.%						
Excitation Wavelength	1064nm						Customizable Doping and Concentration
Output Power	75W(1)	75W(1)	50W(1)	120W(2)	230W(2)	500W(2)	
Crystal Size	∅3×67mm	∅3×78mm	∅3-2×73mm	∅3×67mm	∅4×95mm	∅5×167mm	Other size is customizable
Recommended Water Cooling Temp.	25°C						
Recommended Water Pressure	0.3-0.5MPa						
Recommended Water Flow	>4L/min	>4L/min	>4L/min	>12L/min	>12L/min	>16L/min	
Module Weight	1kg	1kg	1.5kg	1.5kg	3kg	4.5kg	

(1) The output power test condition is: 900mm cavity length, T=20%, parallel plane mirrors.

(2) The output power test condition is: 300mm cavity length, T=20%, parallel plane mirrors.

(*) For more information on pump power, operating current, gain medium specifications, and doping conditions, please contact Lumispot Optoelectronics Group.

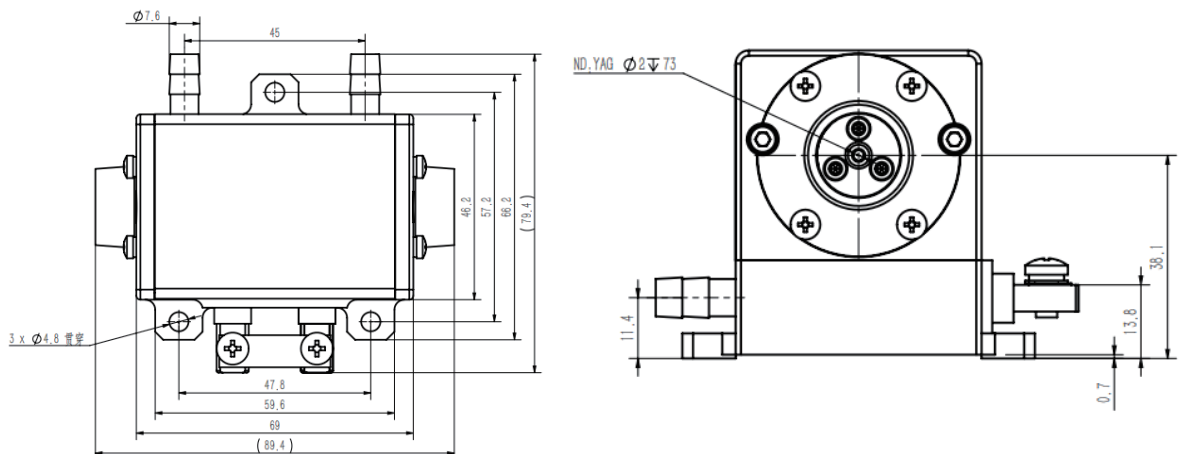

Company Profile

About Lumispot Tech

We're
Lumispot Tech



¥ 78million
Register Capital

6+
Ph.D

80%
Proportion of Talent

150+
Patents



Founded in 2010, Lumispot Technology Group, with its headquarters in Wuxi, boasts a registered capital of CNY 78.55 million. Our expansive facility covers an area of approximately 25,000 square meters and is powered by a dedicated team of over 500 employees. Over the past 14+ years, Lumispot has emerged as a frontrunner in the specialized field of laser information technology, underpinned by a robust technical foundation.

We specialize in the research and development of laser technology, providing a diverse portfolio of products. This range encompasses laser diodes, erbium lasers, fiber lasers, and solid-state lasers, as well as comprehensive systems including laser rangefinder modules, LiDAR lasers, structured lasers, illumination systems, Fiber Optic Gyro (FOG) components, and dazzlers. Our products find extensive applications across various sectors such as defense and security, LiDAR systems, remote sensing, inertial navigation, and technical research.

Contact

Email: sales@lumispot.cn
Website: www.lumispot-tech.com



Illuminate Future From Laser

We aim to become the global leader in laser special information domain.

