

QCW HORIZONTAL STACKS

Features :

- AuSn packed
- Spectral width controllable
- High reliability and long service life
- Wide operating temperature range
- Compact structure

Applications :

- Pump source
- Illumination
- Detection
- Research

LM-X-QY-F-GZ-4

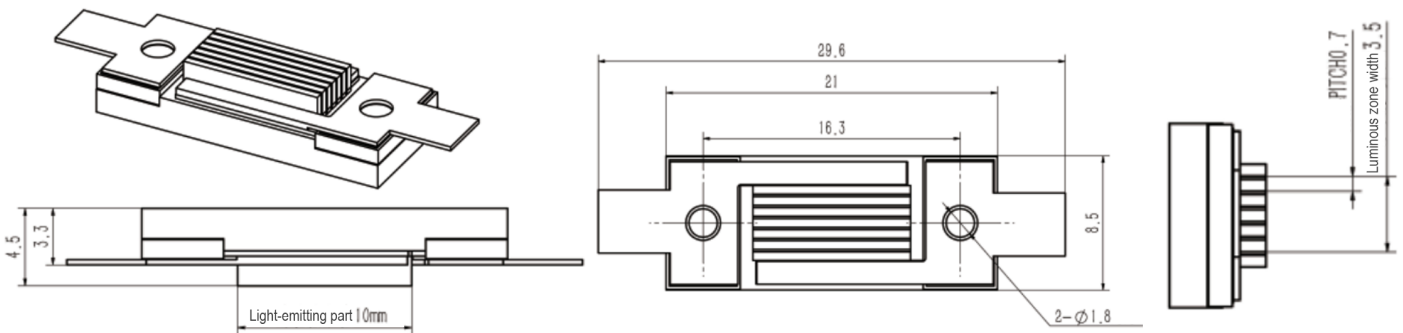
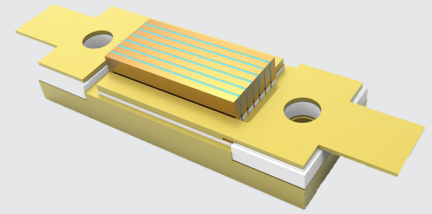

PARAMETERS	Minimum	Typical	Maximum
Peak Power	200W	1200W	1800W
Center Wavelength	790nm	808nm	815nm
Center wavelength tolerance	/	±2nm	/
Beam Divergence(FWHM)	/	8×36 Deg.	/
Wavelength Shift	/	0.26mm/°C	0.28mm/°C
Pulse Width	/	200µs	300µs
Duty Cycle	/	0.4%	1%
Operating Current	/	200A	300A
Power Conversion Efficiency	50%	55%	/
Operating Voltage	/	1.8V	2V

Other

Operating Temperature	- 45°C	25°C	70°C
Storage Temperature	- 60°C	25°C	85°C
Number of Bar	1	6	/
Spacing Between Bars	0.43mm	0.73mm	/

NOTE

1. Specification at around temperature 25 °C, at the initial lifetime
2. Output power & crystal dimension can be customized as needed
3. Follow the LumiSpot Tech operating instruction manual.
4. Any other questions, please contact us.
5. Storage and operation in a non-condensing environment is required at temperatures below ambient.

